

# SAKER SERIES

## Fiber Laser Instruction Manual



浙江宸诺激光智能科技有限公司  
ZHEJIANG CINA LASER TECH. CO., LTD.

## Contents

1. Declaration .....	3
2. Safety Information.....	3
2.1. Laser safety level .....	3
2.2. Safety Protection Measures.....	4
2.3. Security identity .....	4
2.4. Other safety precautions.....	5
3. Product Description.....	5
3.1 Product characteristics .....	5
3.2 Product advantage .....	6
3.3 Main applications.....	6
3.4 Order information.....	6
3.5 Product Technical Specification Sheet.....	7
3.6 Actual configuration list.....	8
3.7 Unpacking and inspection .....	8
3.8 Laser Panel Description.....	8
3.9. Laser control interface definition description .....	9
3.10.Control sequence diagram.....	11
3.11. Power connection.....	11
4.Installation of laser .....	12
4.1.Overall size .....	12
4.2 Installation notes.....	13
4.3. Cooling system requirements.....	15
4.4. Precautions for the cooling system: .....	16
4.5.Water cooling requirements for output cables:.....	16
4.6. Turn on and off the laser.....	17
4.7. Installation and use of the upper computer software .....	17
4.8. Installation and use of Bluetooth applet.....	17
5. Common faults and solution measures .....	18
6.Quality Assurance and Repair and Return Process .....	19
6.1.General warranty .....	19
6.2.ervices and maintenance .....	19
6.3.Change .....	19
Annex 1 SAKER series fiber laser upper computer use instructions.....	20
Annex 2 SAKER series fiber laser WeChat applet use manual.....	24

## 1. Declaration

Welcome to use Zhejiang CINA LASER Tech. Co., Ltd 's (hereinafter referred to as "CINA LASER" or "our company") fiber laser products, this instruction manual applies to the products including CYL-500/S, CYL-1000/S, CYL-1500/S, CYL-2000/S, CYL-3000/S. CYL-500/S、CYL-1000/S、CYL-1500/S、CYL-2000/S、CYL-3000/S。

Before using this product, Please read the user manual carefully and familiarize yourself with the content we have prepared for you. Please put the product specification together with the product to provide you with relevant important information at any time.

### Attention

**We reserve the right to modify the information in this manual without prior notice. CINA LASER believes that the information provided in this manual is accurate and reliable, but CINA LASER does not undertake any warranty regarding the contents of this manual, including but not limited to the implied warranties of merchantability and applicability. Moreover, CINA LASER will not be liable for any patent infringement or damage to the rights and interests of any third party caused by the use of this manual. CINA LASER will not be responsible for any error information in this manual. CINA LASER is not liable for any accidental or indirect consequences arising from the provision, execution, or use of this manual.**

Direct or indirect use of the information provided in this manual does not mean that CINA LASER authorizes any patent or other intellectual property.

Zhejiang CINA LASER Tech. Co., Ltd. All rights reserved. This content is not allowed to be reproduced, transmitted, stored, or adapted for publication in any form or method without the written authorization of CINA LASER, unless permitted by the relevant copyright law.

## 2. Safety Information

### 2.1. LASER SAFETY LEVEL

This product belongs to Class 4 laser products, output high power invisible laser, wavelength  $1080\pm 10\text{nm}$ , will cause damage to eyes or skin directly or indirectly exposed to this strong laser, may also cause a fire on site, so please strictly follow the EU EN60825-1:2014 standard, all personnel operating or near the laser must be aware of these special hazards. Wear wavelength-matched and certified laser protective eyewear and take adequate safety precautions.





## 2.2. SAFETY PROTECTION MEASURES

NO	ITEM	DESCRIPTION
1	Safety/Warning signs	Remind and warn installation and operation personnel of possible hazards.
2	Self-lock, Interlock, Alarm	Built-in safety control sensors, including temperature, current and voltage, optical circuit, QBH and other monitoring, to achieve automatic safety self-locking. It can be connected to water cooler and other safety interlock signals for product external interlock connection control;
3	External Communication Security Control	Set communication port for external safety emergency stop control.

## 2.3. SECURITY IDENTITY

Laser safety identifiers include: safety warnings, laser output head warnings, laser radiation markings, product nameplates, etc. Safety and information marking details are shown in Table 1 as follows:

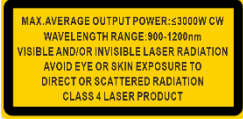
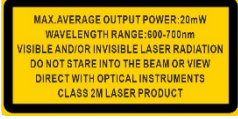
Table 1 Laser identity

IDENTITY	DESCRIPTION
	Laser radiation danger signs, please wear laser protection glasses, and strictly forbid any part of the body exposed to the laser.
	Laser output warning signs, please wear laser protective glasses, strictly forbidden to expose any part of the body to the laser
	Class 4 laser products, avoid direct exposure to human eyes, please wear laser protective glasses, it is strictly prohibited to expose any part of the body to the laser.
	2M class laser products, avoid direct exposure to human eyes, please wear laser protective glasses, it is strictly prohibited to expose any part of the body to the laser.
	Beware of electric shock signs, confirm the need for electricity before use, and pay attention to the safety of electricity.
	The nameplate, including the product model number and SN, etc.

## 2.4. OTHER SAFETY PRECAUTIONS

- 1) Before powering up the laser, make sure the protective cap on the QBH fiber output head has been removed and carefully checked and wiped to ensure that the crystal end face of the QBH fiber is clean to avoid damage to the laser, see the QBH fiber interface connection instructions for details.
- 2) After the indicator light is turned on, it is strictly forbidden to expose the eyes to the indicator light to avoid injury.
- 3) The laser is infrared invisible light, after the laser is turned on, it is strictly prohibited to expose any part of the body to the laser to avoid personal injury.
- 4) Special laser protection glasses must be worn when installing and operating this product. Please select laser protective glasses according to the laser wavelength range and power level. Do not look directly at the output head while the laser is powered on, even if you are wearing laser protection glasses.
- 5) Please replace the cooling water of the water cooler regularly to avoid blockage of the laser water cooling module due to cooling water decay.
- 6) When operating the laser in winter, please add antifreeze to the cooling water in the right proportion according to the local temperature to avoid internal damage to the laser caused by icing.
- 7) If the laser is not used for a long time, please empty the cooling water inside the laser in time. Cover the output head protection cap, good dustproof.
- 8) Please make sure the PE wire of the power cord is grounded reliably to avoid losses.
- 9) Ensure that the AC voltage supply is normal, incorrect wiring or supply voltage can cause irreversible damage to the equipment.
- 10) Do not open the laser casing without devices inside the laser that require maintenance to avoid personal injury.
- 11) Do not damage the tamper-proof label on the laser housing to avoid loss of warranty rights.

## 3. Product Description

### 3.1 PRODUCT CHARACTERISTICS

CINA LASER CYL-500W-3000W single-mode 1.0 $\mu$ m continuous fiber laser uses the latest technology and optimum design. It has the advantages of high electro-optical conversion efficiency, long service life, high safety, and reliability. With good output beam quality and strong anti-high reflective ability, which can be widely used in laser cutting, welding, drilling, 3D printing and other fields.

CINA LASER has established a scientific after-sales service system with Internet technology. Each equipment has a unique identity code (that stores the original technology and material information of the machine), which can be used for remote real-time monitoring online, providing users with fault warning, quick technical support and after-sales service.

CINA LASER with its high quality, high reliability and excellent cost performance, can meet the diverse needs of customers, customization and good after-sales service, which is an ideal choice for

system integrators and equipment manufacturers.

### 3.2 PRODUCT ADVANTAGE

- High electro-optic conversion efficiency greatly reduces power consumption cost.
- Strong anti-high reflective ability, suitable for processing different materials
- Remote real-time monitoring.
- Long service life, high safety and reliability.
- Personalized customization.
- Good after-sales service system.
- Excellent performance-to-price ratio

### 3.3 MAIN APPLICATIONS

Laser cutting, laser welding, laser cladding, laser brazing, laser surface heat treatment, etc.

### 3.4 ORDER INFORMATION

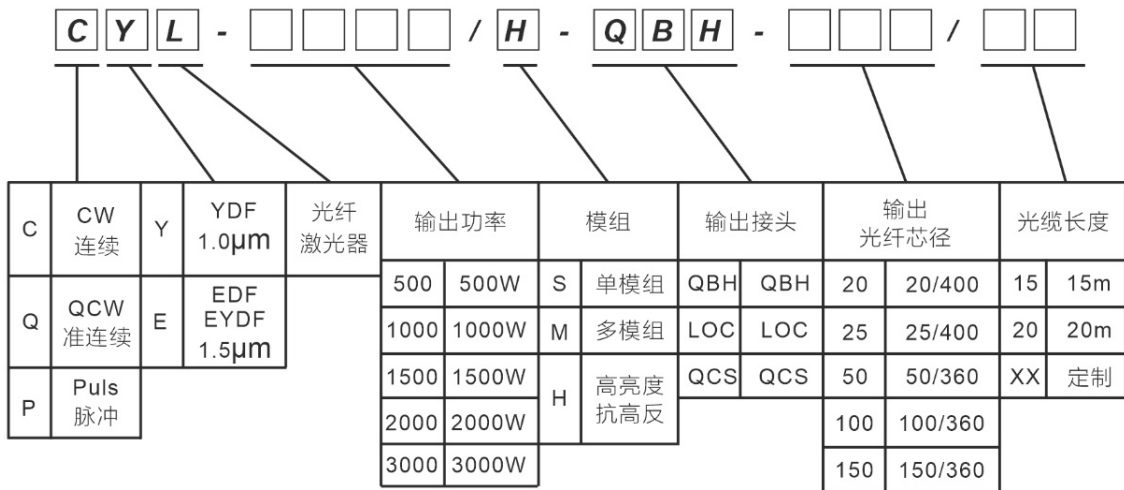

### 3.5 PRODUCT TECHNICAL SPECIFICATION SHEET

#### Product Technical Parameter

Performance		Min.	Typ.	Max.	Remarks		
Optical characteristics	Central wavelength	(nm)	1070	1080	1090		
	Spectral bandwidth	(nm)		3	5	-3dB	
	Output optical power	CYL-1000/S	(W)		1000		
		CYL-1500/S			1500		
		CYL-2000/S			2000		
		CYL-3000/S			3000		
	Short time power stability	(%)	±1				
	Long time power stability	(%)	±2				
	Laser opening time	(μs)	50~100				
	Laser shutdown time	(μs)	100~200				
	Power regulation range	(%)	10		100		
	Beam quality	(M <sup>2</sup> )			1.2	QBH-20,25	
					1.8	QBH-50	
					3.6	QBH-100	
	Fiber numerical aperture (NA) half angle	(rad)			0.065	QBH-20,25	
				0.22	QBH-50、100		
Modulation frequency	(KHz)	5		20	100%output		
Red light Power	(mW)	5		60			
Output characteristics	Output connector			QBH	Customizable		
	Output fiber core diameter	(μm)	20	50	100	Customizable	
	Output fiber length	(m)		10	15	Customizable	
	Output cable bending radius	(mm)	200				
	Work model		Continuous/modulation			CW/Modulate	
	State of polarization		Random			Random	
Electrical cooling characteristics	Communication interface		RS232				
	Remote communication		APP			Customizable	
	Power supply	(V)		220			
	Power consumption	CYL-1000/S	(KW)			3.0	220V, Single phase three
		CYL-1500/S				4.5	
		CYL-2000/S				6.0	
		CYL-3000/S				8.8	
	Cooling mode		Water cooling			External	
	Cooling water temperature	(°C)	21		25		
	Cooling water flow	CYL-1000/S	(L/min)		10		
CYL-1500/S				20			
CYL-2000/S				25			
CYL-3000/S				40			
Working ambient temperature	(°C)	10		40			

General characteristics	Working environment humidity		(%)	10		85	
	Storage temperature		(°C)	-10		60	
	Structure			Rack			
	Weight/ Size	CYL-1000/S	(kg)	23	W× L× H (mm)	482.6(447)×514.5×79	
		CYL-1500/S		26		482.6(447)×514.5×79	
CYL-2000/S		34		482.6(447)×641.5×79			
CYL-3000/S		42		482.6(447)×711.5×79			

### 3.6 ACTUAL CONFIGURATION LIST

Please refer to the packing list in the packing box.

### 3.7 UNPACKING AND INSPECTION

Through specially designed packaging materials and boxes, CINA LASER ensures that the laser can always be fully protected during transportation. Nevertheless, to prevent the unpredictable situation in the transportation process, the user still needs to carefully check whether the packing box is placed correctly and whether there is any damage such as collision, cracking and flooding outside the box before opening the box. Once the external box is found to be abnormal, please inform CINA LASER in time so that we can deal with it as soon as possible.

After unpacking, please check whether the packing list is consistent with the actual items. If in doubt, please contact CINA LASER in time.

Open the box to remove the laser should be careful to avoid collision or violent vibration to the laser. When removing the coiled laser output cable, special care should be taken not to twist, bend or pull the laser output cable, and the laser output head should be protected from collision and vibration.

**Open the protective cap on the end of the output fiber and observe that there should be no stains or cracks on the output end face. Be careful not to contaminate the output end face.**

The laser should be placed on a flat, firm table and ensure ventilation.

### 3.8 LASER PANEL DESCRIPTION

Front panel of the product



- ① **POWER:** power indicator light, blue light indicates that the power is on.
- ② **LASER:** laser indicator light, yellow light indicates that the laser is working.
- ③ **ALARM:** alarm indicator light, red light indicates the machine failure.
- ④ **EMERGENCY:** emergency stop switch, press it to turn off the laser immediately and rotate clockwise to release the button. Use the power switch to power on the laser again to return to normal.
- ⑤ **AC POWER:** Power switch, press the ammonium button is always on, open the laser.



Rear panel of the product



**1 WATER IN 和 2 WATER OUT :** For the water inlet and outlet of the laser. For the inflow and return of cooling water, this interface for the inner diameter  $\Phi 16$  quick plug connector or outer diameter  $\Phi 19$  pagoda connector, suitable for the installation of outer diameter  $\Phi 16$  or inner diameter  $\Phi 19$  water pipe connection.

**3 External (Bluetooth) antenna:** For receiving Bluetooth signals.

**4 CDA check valve:** Dry, clean air interface, access to dry and clean compressed air (0.1Mpa) to prevent the laser from condensation, prohibit the use of compressed gas with water, with oil.

**5 Control Interface (Control) :** DB25 control signal connection port with external board for external control mode to control or operate the laser.

**6 Control Interface (RS232) :** DB9 is used to connect to the host computer, through the host computer software to enter the debugging mode, the host computer software for internal control of the laser operation, or query the status of the laser.

**7 AC INPUT:** AC 220V/380V voltage input interface, see 3.5 product technical specifications table power supply requirements.

**8 Laser output fiber optic cable (Laser) :** Fiber optic armored cable with laser output.

### 3.9. LASER CONTROL INTERFACE DEFINITION DESCRIPTION

1) RS-232 Serial Port Introduction:

Pin NO.	Definition
2	TX
3	RX
5	GND
Other	Idle

USB转串口线  
PL2303芯片兼容32/64位WIN10

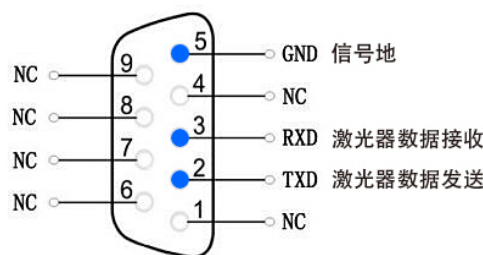

2) **DB25** control signal interface: the pin definition is shown below:

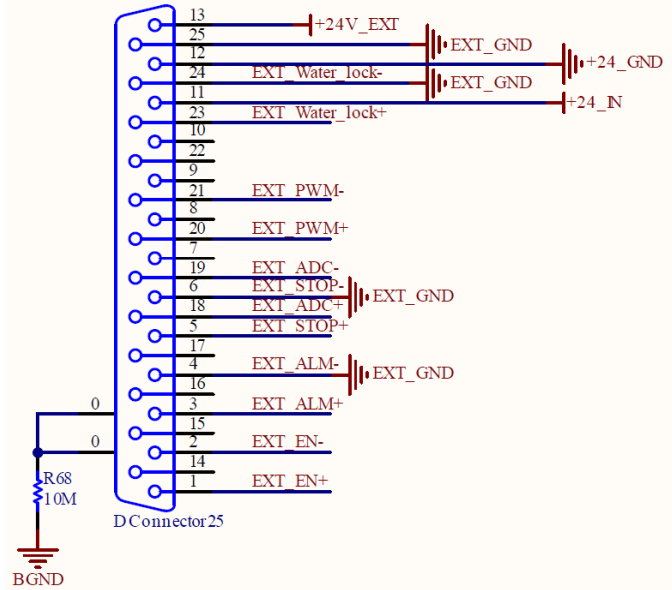

PIN NO	Definition	Drive Capability	Description
13	Output 24V positive	Output current $\leq 40\text{mA}$	Small power 24V power output
25	Output 24V negative		
12	24V Standby input negative	Input current $\geq 800\text{mA}$	Commissioning power supply, not needed for normal operation
11	24V standby input positive		
24	Negative interlock of water cooler	Shorting resistance $\leq 200\Omega$	The water cooler should be shorted or pulled down when normal
23	Positive water cooler interlock		
21	PWM signal negative	Input current $\geq 5\text{mA}$	Laser PWM modulation signal
20	PWM signal positive		
19	ADC signal negative	Input current $\geq 1\text{mA}$	Laser analog modulation signal, input 1-10V corresponding to 10%-100% laser peak power
18	ADC signal positive		
6	Emergency stop signal negative	Shorting resistance $\leq 200\Omega$	external emergency stop trigger signal. Shorted or pulled down to trigger emergency stop
5	Emergency stop signal positive		
4	Alarm signal negative		Laser alarm signal, internal 10K $\Omega$ pull-up optocoupler output, normal 24V, low level output in alarm
3	Positive alarm signal		
2	Enable signal negative	Input current $\geq 5\text{mA}$	
1	Positive enable signal		

Note: please check the level of the control signal to ensure compliance. Voltage excess or voltage fluctuation may damage the laser. Ensure that the analog voltage signal does not exceed 10.5V, otherwise the laser may be damaged.

### 3.10. CONTROL SEQUENCE DIAGRAM

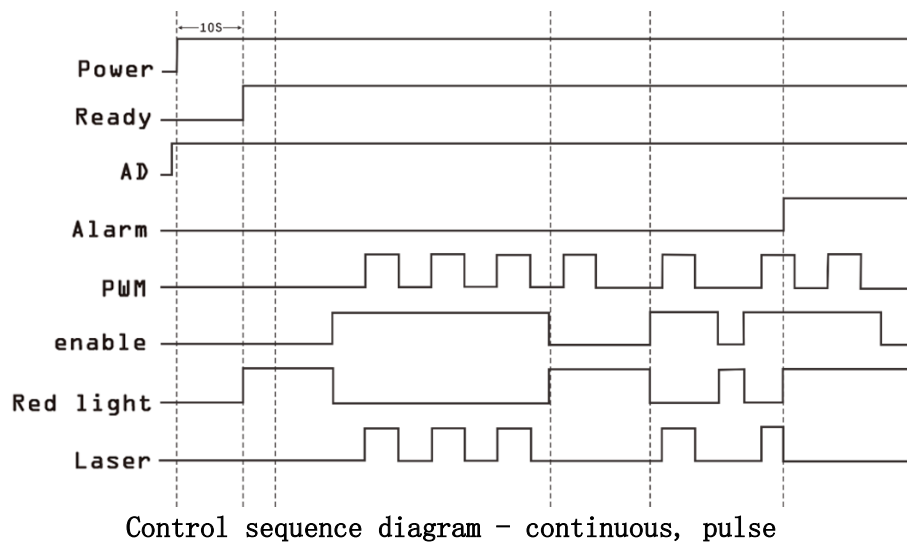

### 3.11. POWER CONNECTION

- 1) before connecting to the AC power supply, please check that the laser model is consistent with the AC power supply below.
- 2) The wrong connection will cause damage to the laser, so please check that the power cord connection is correct before the laser is powered on.

#### Power outlet

The other end of the power supply is a stripped three-strand wire, which marks as, L1, N and PE. It can be connected to 220V AC power supply according to the wire mark. The power cord must be reliably connected as shown in the table before the laser is powered on.

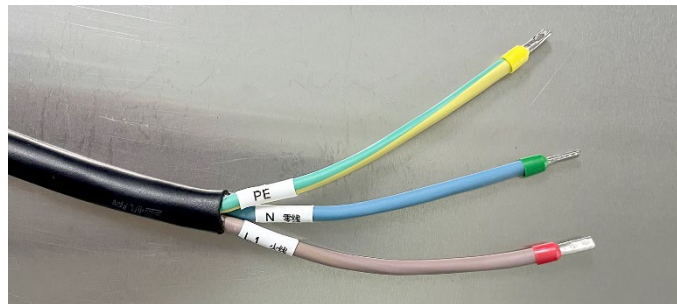

Makes	Color	Definition
L1	brown	Fireline
N	blue	Zero line
PE	yellowgreen	Grounding

#### power-line connection:

Depending on the power of the laser, CINA LASER will provide two specifications of power cords: single-phase three wire or three-phase five wire power cords.

**single-phase three-wire power cords:** Using 220V circuit breaker wiring, with a rated working current of not less than 60A.

**Three phase five wire:** The wiring adopts a 380V circuit breaker with a rated working current of not less than 100A.

**All circuit breakers used must be effectively grounded and connected to the power cord in a power outage state.**

If the voltage fluctuation in the end user area exceeds  $\pm 5\%$ , which exceeds the requirements of this product, please configure a suitable power supply.

## 4. Installation of laser

### 4.1. OVERALL SIZE

Outline and Installation Dimension Drawing of Laser Products (Unit: mm)

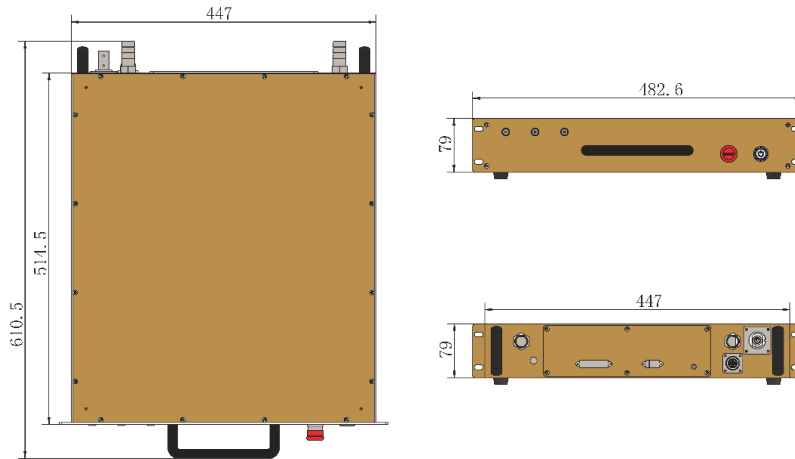

**CYL-1000/S、CYL-1500/S Dimensional drawing**

NO	Model	H/mm	W/mm	L/mm	Weight/kg
1	CYL-1000/S	79	482.6(447)	610.5(514.5)	23
2	CYL-1500/S	79	482.6(447)	610.5(514.5)	26

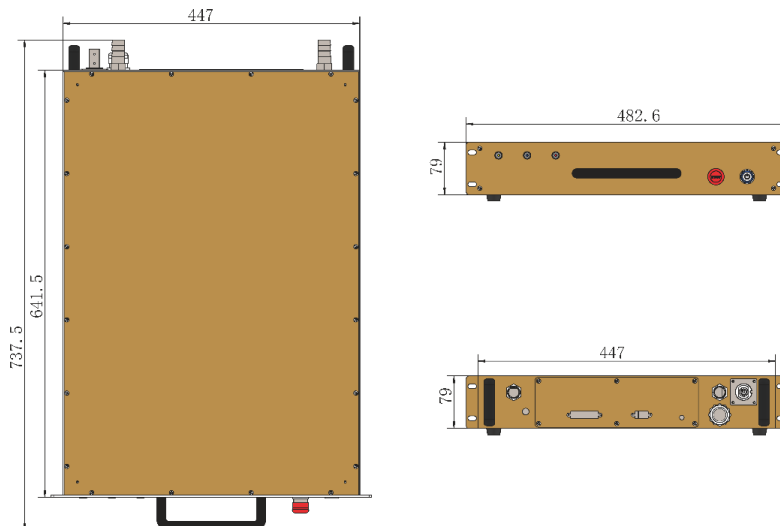

**CYL-2000/S Dimensional drawing**

NO	Model	H/mm	W/mm	L/mm	Weight/kg
1	CYL-2000/S	79	482.6(447)	737.5(641.5)	34

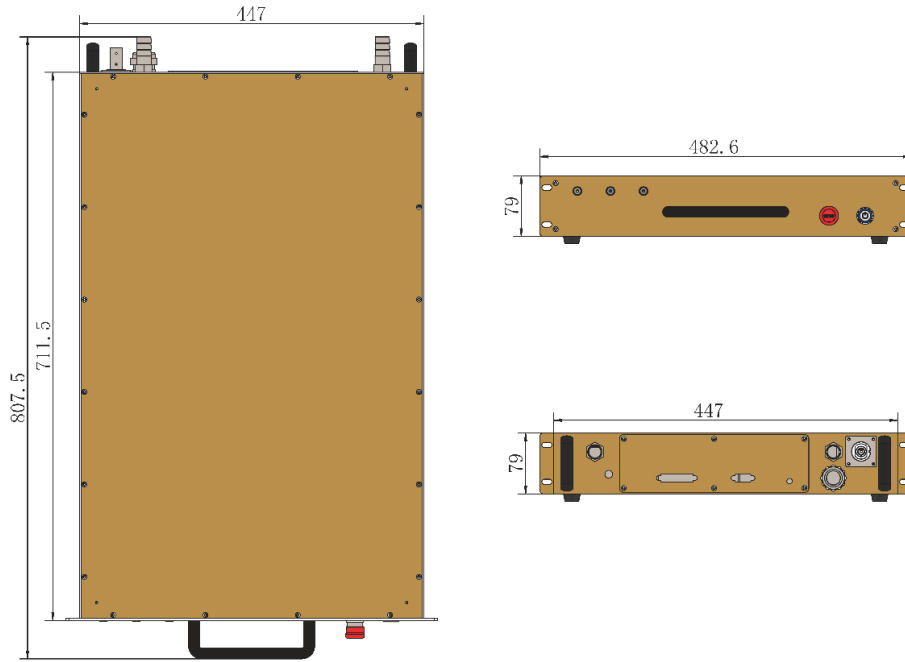

CYL-3000/S Dimensional drawing

NO	Model	H/mm	W/mm	L/mm	Weight/kg
1	CYL-3000/S	79	482.6(447)	807.5(711.5)	43

QBH Output head (unit: mm)

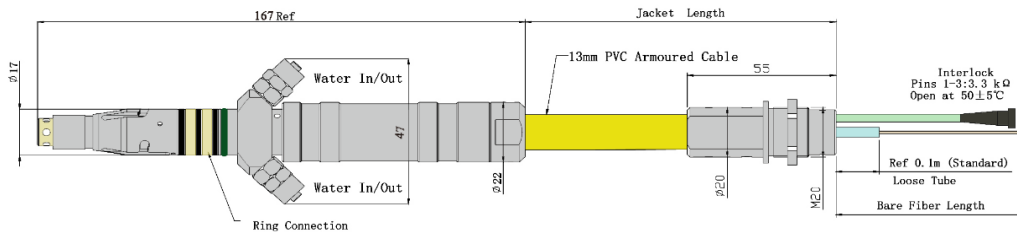

## 4.2 INSTALLATION NOTES

1. Place the laser horizontally in a suitable position and make the necessary fixing;
2. Check that the laser power supply and grounding are good before powering up the laser;
3. Connect the power and control cables of the laser in an unpowered state;
4. Connect the cooling system to the laser and the output head according to the inlet and outlet water markings;
5. Securing the output head before it is loaded into the processing head;
6. Ensure that the emergency stop button is pressed and the laser is disconnected from power and that the quartz end face of the output QBH fiber is checked for any contamination after the QBH fiber protection cap is removed, otherwise it must be cleaned prior to operating the laser.
7. The process of installing the jumper output head should ensure the cleanliness of the surrounding environment (do not use electric fans to dissipate heat when it is hot in summer as

a way to avoid having large dust in the air). In a dust-free environment, remove the dust cap and observe whether there is residual dust on the end face of the quartz crystal under the light (use a microscope to observe in a dust-free environment if necessary), if dust-free conditions cannot be achieved, always make sure the end face is down when inspecting the actual plant.

If cleaning is required, proceed as follows:

Secure the QBH to the QBH clamping fixture;

Place a special wipe paper on the QBH window sheet and dab a small amount of isopropyl alcohol on the wipe paper on the QBH end face with a round tipped cotton swab;

Drag the wipe paper in one direction to clean the end face and wipe away any dust or dirty spots;

Observe the end face under a microscope to see if it is clean and free of dirty spots, if there are dirty spots repeat the above two steps;

Attention to all cleaning auxiliaries should not be reused.

8. Do not step on, squeeze or excessively bend the protective sleeve during the installation of the jumper to avoid damage to the fiber.

9. The minimum bending diameter of the optical fiber shall not be less than 20cm in transportation, storage and other non-working conditions; the minimum bending diameter shall not be less than 30cm in the laser outgoing light state.

10. When using the CDA interface function, dry, cooled air must be used after the cold dryer, and then filtered through the 5um and 0.3um particle filter, and 0.1um oil mist filter respectively, the temperature of the gas must be in the range of 5-40 °C (close to the temperature of the main laser water supply), the air pressure is less than 0.1MPa, and the interface is a 4mm or 6mm quick plug connector.

<b>Constant dew point table at ambient temperature and relative humidity</b>									
Ambient temperature °C	Maximum relative humidity								
	20%	30%	40%	50%	60%	70%	80%	90%	95%
20	-3.5	2	6	9	12	14.5	16.5	18	19
25	0.5	6	10.5	14	16.5	19	21	23	24
30	4.6	10.5	15	18.5	21.5	24	26	28	29
35	8.5	15	19.5	23	26	28.5	31	33	34
40	13	20	24	27.5	31	33.5	36	38	39
<b>Laser operating temperature range</b>									

**Note: Damage to the laser caused by condensation is not covered by the laser's normal warranty!**

11. When using the CDA interface function in a high temperature, high humidity environment, it is necessary to start venting the laser 30min before the laser is watered out to reduce the humidity inside the laser and ensure that there is no condensation inside the laser. When the ambient temperature is 10°C lower, the CDA interface can be used without it.

12. QBH and laser processing head installation: Before powering up the laser, you must ensure that the

QBH is reliably connected to the laser processing head. It is strictly forbidden to power up the laser while checking the QBH end face or installing the QBH.

a) The laser fiber will be stretched out, the length should make the fiber connector can reach the farthest end of the machine movement, the fiber must not be twisted to avoid long-term movement to cause breakage.

b) Clean the fiber optic: put the fiber optic connector into a clean box or clean table, use a dust-free wiping cloth with isopropyl alcohol, wipe the outer surface of the laser head, fiber optic connector, microscope, cable water pipe near the fiber optic connector and other devices with a dust-free cloth to ensure that the area near the fiber optic connector will not raise dust. Operators should wear rubber gloves and wash their hands to keep them clean and dust-free.

c) Laser head cleaning: remove the laser head, put the laser head into a dust-free box, and use a dust-free wipe to clean the laser head surface, especially the QBH interface surface, the collimation protection mirror module surface, and the focus protection lens module surface to ensure that there is no dust.

d) Optical fiber inserted into the laser head operation steps:

Place the laser head horizontally to prevent dust from falling in and align the clean fiber optic connector horizontally with the QBH socket. Find the two red dots on the QBH and one red dot on the fiber optic connector, align the red dots, connect them into a straight line, and insert the fiber optic plug into the QBH.

Turn the QBH locking ring clockwise to fix it, lift up the locking ring and turn it clockwise again to complete the locking. Check whether the fiber optic locking ring is secure.

### 4.3. COOLING SYSTEM REQUIREMENTS

In order to ensure the stable and reliable operation of the laser, a water cooler with dual temperature control (with both heating and cooling functions) must be used and work without interruption.

When installing and using the cooling system for the first time, the whole water system and joints should be checked for leaks, and the external water pipes must be installed and connected according to the water inlet and outlet requirements marked by the laser, otherwise the laser may not work properly.

This single-mode fiber laser products have two places need to pass cooling water for heat dissipation treatment. The first place is the main laser, the water inlet and outlet interface is located at the rear panel of the laser. The second is the QBH fiber output.

Cooling Requirement/Model		CYL-1000/S	CYL-1500/S	CYL-2000/S	CYL-3000/S
Laser Cooling	Cooling capacity	≥3.5KW	≥4KW	≥5.5KW	≥8.0KW
	Flow rate	>10L/min	>20L/min	>25L/min	>40L/min
	Laser interface	Quick plug connector for OD 16mm/ID 12mm water pipe		Pagoda, ID 19mm water pipe	
	Pressure	≤0.5Mpa			

<b>QBH Cooling</b>	Temperature setting	25±1°C
	Temperature setting	28-30°C
	Flow rate	1.5-2.0L/min
	Water cooler hose	DN>8Water pipe, length < 15m
	QBH water-cooling interface	Quick release coupling to OD 6mm water pipe, length < 1m

Water temperature setting for the cooling system: **24±1°C**。 before turn on the laser, please ensure the cooling system work normally, and the water temperature reaches **21°C**。

**4.4. PRECAUTIONS FOR THE COOLING SYSTEM:**

- (1) The cooling water should be deionized water or distilled water, and the use of tap water is strictly prohibited.
- (2) prevent mold growth in the chiller from clogging the pipe, it is recommended to add ethanol when filling the purified water. The amount of ethanol should be 10% of the purified water.
- (3) When the ambient temperature of the equipment is -10°C ~ 0°C, ethanol solution with a volume ratio of 30% must be used and replaced every two months.
- (4) When the ambient temperature of the equipment is below -10°C, a dual-function chiller must be used and the cooling system must be kept in continuous operation.
- (5) Please empty the water inside the equipment and QBH when shutting down for a long time, otherwise it will cause damage to the laser equipment. Cooling water is recommended to be replaced once every two months. The air pressure must be less than 0.1Mpa when draining the water inside the QBH, so as to avoid damage to the fiber by excessive air pressure.
- (6) It is necessary to prevent internal condensation when using the laser in summer. Once the cooling temperature of the water cooler falls below the dew point temperature of the laser's internal environment, water vapor in the air will condense on the electrical and optical modules. If no measures are taken, condensation will follow on the external surface of the laser. Therefore once condensation is seen on the laser housing, it means that condensation has formed inside the laser. It is necessary to immediately power down, stop working and improve the laser working environment.

**4.5.WATER COOLING REQUIREMENTS FOR OUTPUT CABLES:**

Cooling water flow: 1.7-2.0L/min

Water cooling pressure: inlet less than 0.6Mpa

Water pipe type: outer diameter  $\phi 6$  inner diameter  $\phi 4$

Cooling water direction: unidirectional, connect the water pipe in strict accordance with the water inlet and outlet direction marked on the shell.

Cooling water quality: deionized water, distilled water, purified water



Cooling water PH range: 5.5-9

A water cooler shall be equipped with a filter element with a filter particle size of less than 100 um.

Max. cooling water temperature: 40°C

Min. cooling water temperature: higher than saturated dew point temperature 5°C

Additives in cooling water: meet the above requirements of PH values and solid particle size

Long-term vibration, less than 2G; impact, less than 10G.

#### **4.6. TURN ON AND OFF THE LASER**

When the laser is turned on, it enters the external control mode. In the external control mode, the output power is controlled by the magnitude of the external analog voltage signal; the laser output is controlled by the external enable and external modulated PWM signals.

Please connect the water circuit according to the panel interface requirements, the cooling system needs to meet the requirements, connect the power cord according to the correct connection to ensure reliable grounding; connect the external control cable to the control interface, the other end according to the wiring definition, connect to the machine corresponding to the control signal port. The water cooling interlock and safety interlock of the switch and interlock port are connected in parallel with the water cooling interlock and safety interlock in the control interface definition, both can be connected to only one place.

Before powering up the laser, check the laser status for the following requirements:

The flow and temperature of the water cooling system meet the requirements;

the power and control lines are properly connected and the input voltage meets the product requirements;

The emergency stop button is in the pop-up state;

the interlock signal of the laser is connected in series with the output fault signal of the water cooler and the door switch signal to better protect the laser and the safety of the operator;

The laser is powered on, the POWER indicator lights up, the laser is powered on for self-test, and the laser is ready to receive analog signals after 10s.

In the external control mode, when the laser's external enable signal has been provided as required, the laser will output the corresponding 10%-100% power according to the external modulated PWM signal's high level status, in accordance with the size of the external analog quantity 1-10V.

When the laser fails and needs to be powered off, the laser needs to wait for about 20s before it can be powered on again after the laser is powered off.

#### **4.7. INSTALLATION AND USE OF THE UPPER COMPUTER SOFTWARE**

The installation and use of the upper computer software is detailed in Annex 1 - "SAKER series fiber laser upper computer use instructions

#### **4.8. INSTALLATION AND USE OF BLUETOOTH APPLLET**

The installation and use of the Bluetooth applet is detailed in Annex 2 - "SAKER series fiber laser WeChat applet use manual

## 5. Common faults and solution measures

This laser has detection functions for optical path, temperature, current, input voltage, QBH, etc. If abnormalities occur during operation, the alarm area of the control software will display the fault. The common faults of this laser and the measures to solve them are shown in the following table.

**Common failures of lasers and solutions**

NO	Fault name	Description and solution
1	<b>Trip</b>	Please check if the power supply line is connected correctly and the circuit breaker power is stagnant to meet the requirements.
2	<b>Interlock-Water cooling fault</b>	The water cooler is not turned on or stopped due to malfunction, please check if the water cooler is working.
3	<b>QBH</b>	The QBH is not connected to an external cutting head. Make sure the QBH is securely connected to the cutting head and the laser is re-powered before proceeding accordingly.
4	<b>Emergency stop alarm</b>	This alarm will appear when the emergency stop interlock signal is a short circuit, or when the front panel emergency stop is pressed. Please make sure that the emergency stop interlock signal is not faulty, and also check that the emergency stop button is popped up. Re-energize the laser and operate accordingly.
5	<b>Password alarm</b>	If the front panel alarm light flashes, it means the trial period of the laser has expired, please contact after-sales for the unlock code.
6	<b>Optical circuit alarm</b>	Re-apply power, make sure there is red light output, and then turn on the laser again. When there is no red light output, please contact our after-sales service.
7	<b>Temperature Failure</b>	When this problem occurs, make sure that the flow rate of the water cooler meets the requirements. Increase the output flow rate of the water cooler to the required product value and restart the laser.
8	<b>Temperature Alarm</b>	When there is a temperature alarm, determine whether the output flow rate and output water temperature of the water cooler meet the product requirements. When the lower temperature limit appears, it means the input water temperature of the laser is too low; when the upper temperature limit appears, it means the input water temperature of the laser is too high, or the flow rate is too low.
9	<b>Current Alarm</b>	Re-apply power, make sure there is red light output, and then turn on the laser again. When there is no red light output, please contact our after-sales service.

**When a malfunction occurs and the laser needs to be powered off, please wait for about 20s after the laser is powered off and then power up the laser again for subsequent operations.**

**If the fault cannot be removed after taking the above measures, please contact our company.**

## 6. Quality Assurance and Repair and Return Process

### 6.1. GENERAL WARRANTY

Unless otherwise specified, CINA LASER provides a 24-month warranty for all products for material defects and quality problems (from the date of shipment). CINA LASER will choose 1) repair 2) replace 3) refund products that are confirmed to be defective and still within the warranty period. All repaired or replaced products continue to use the initial warranty period of the original repair product, that is, free repairs can be submitted only during the remaining warranty period of the original repaired product. The buyer must submit written repairs within 30 days after finding any quality problems. All repair requests must be submitted directly by the buyer, CINA LASER will not accept any third party repair requirements.

**The above repair is not applicable to product problems caused by the following situations:**

- 1) Incorrect or improper maintenance or calibration performed by non-CINA LASER personnel.
- 2) Software, interfaces or power supplies provided by customers or third parties.
- 3) Unauthorized maintenance or repair, incorrect operation beyond the limits of product parameters.
- 4) Abuse, negligence, accident, loss or damage during transportation;
- 5) Output termination (contains bare fiber, fiber optic cable, fiber termination, protective mirror, external coupler and collimator);
- 6) The transmission fiber is not covered by the warranty.

The technical guidance and service provided by CINA LASER to customers will not affect the warranty terms provided by CINA LASER.

### 6.2. SERVICES AND MAINTENANCE

All repair or replacement products must be placed in the original box provided by the company, otherwise the company will have the right not to repair any damage caused by the product free of charge.

When you receive our products, please check whether the products are intact or not, and if there is any abnormality, please contact the carrier and our company in time.

Please do not mail any product back to our company without communication confirmation, otherwise it will be rejected and returned for processing, and the resulting loss will be borne by the customer.

### 6.3. CHANGE

We reserve the right to change the design and structure of the products, and we will not be responsible for any modification of the same model products that have been sold.

**\*All the above terms and conditions are interpreted by CINA LASER.**

浙江宸诺激光智能科技有限公司  
ZHEJIANG CINA LASER TECH. CO., LTD.

# Annex 1 SAKER series fiber laser upper computer use instructions

## I 、 General

The host computer software can read the laser operation status, alarm information, device activation, parameter setting and other functions in real time.

The host software described in this manual is applicable to Falcon series fiber laser (model RXXXXXXXXXX).

## II 、 Software Installation

Copy the " Cinalaser Installer " application from the USB drive to your computer, right-click and select "Run as administrator", select the installation location, and follow the prompts to install it.

## III、 Instructions for the use of the upper computer

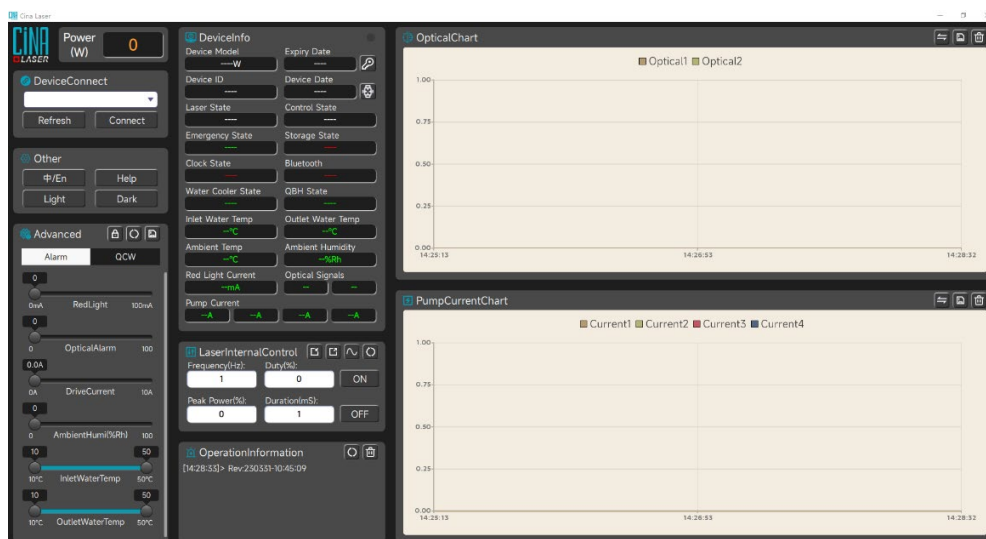

The top left corner of the software shows the current peak power output of the device.

**Device Connection:** Click the **Refresh** button to scan all currently recognized serial devices. Select the COM number of the laser and click on the **connect** button to connect.

### Panel Introduction

#### 1. Other settings

Include Chinese and English switch, open software help file, switch light and dark theme function.



## 2. Advanced Settings

There are 3 buttons on the right side of the Advanced Settings heading, the first button is to **re-lock** the Advanced Settings panel, the second button is to **refresh** the current parameters, the third button is to **save** the modified parameters to the device, **Alarm Parameters Settings** and **QCW Parameters Settings**, need to enter the password to open, the password is **XXXXXXX**.

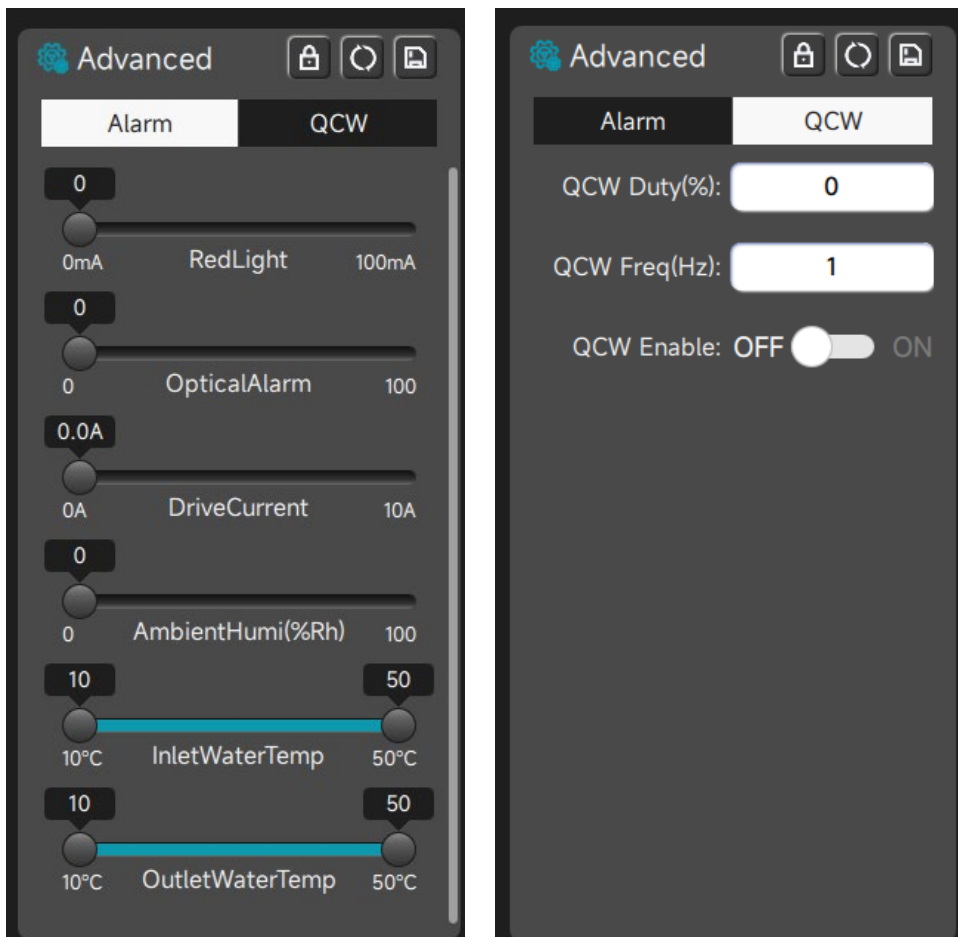

### Alarm Parameters:

- **Red light intensity** is used to set the red light drive current size
- **Photoelectric alarm threshold** is used to determine the photoelectric alarm
- **Drive current alarm threshold** is used to drive current alarm
- **Ambient humidity alarm threshold** is used to determine the humidity alarm, this alarm does not affect the laser work
- **Inlet water temperature alarm threshold** is used to delineate the water temperature range of the water cooler input to the laser
- **Output water temperature alarm threshold** is used to delineate the water temperature range from the laser output to the water cooler

**QCW Parameters:**

- **QCW duty cycle** sets the duty cycle of the quasi-continuous pulse, the percentage of output time per unit cycle
- **QCW frequency** sets the frequency of the quasi-continuous pulse, the higher the frequency, the shorter the unit cycle
- **QCW enable** sets the enable and disable of QCW function

**3. Equipment Information**

After successfully connecting the device, the **green light** in the upper right corner will flash, indicating successful reception of data. If it stops flashing, please check whether the COM number of the device is selected correctly and whether the DB9 interface is firmly connected, and each text box will display the current operating status value of the device when the green light in the upper right corner keeps flashing. The key icon button to the right of the cut-off date is the device activation button, and the watch icon to the right of the device date is the time calibration button.

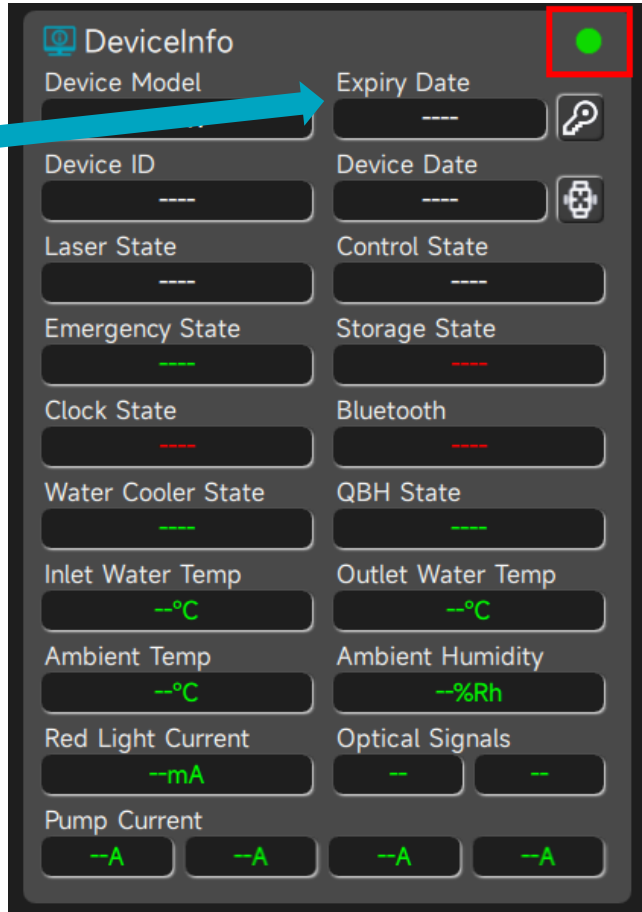

**If the following conditions occur, you need to contact the manufacturer for time calibration and reactivation.**

1. The device is in trial period and the clock status is displayed incorrectly, if it is permanently activated, you don't need to care about the clock status and device date.
2. Storage status is incorrectly displayed.
3. Expiration date is shown as expired.

**4. Laser Internal Control**

Laser internal control panel, the top right 3 buttons are, respectively, switch internal control mode, switch external control mode and refresh the current parameters (read back from the device)

The light output parameters include laser peak power, laser PWM frequency, laser PWM duty cycle, and single light output duration.

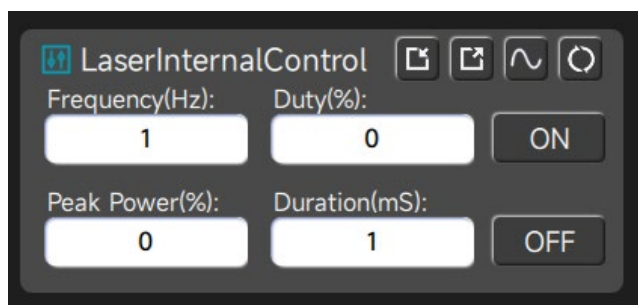

## 5. Operation Information

Status information when the device is running.

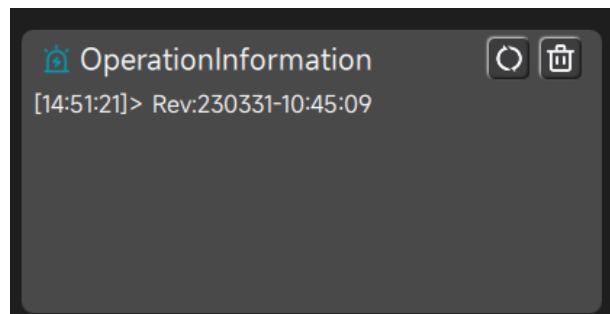

## 6. Change Curve

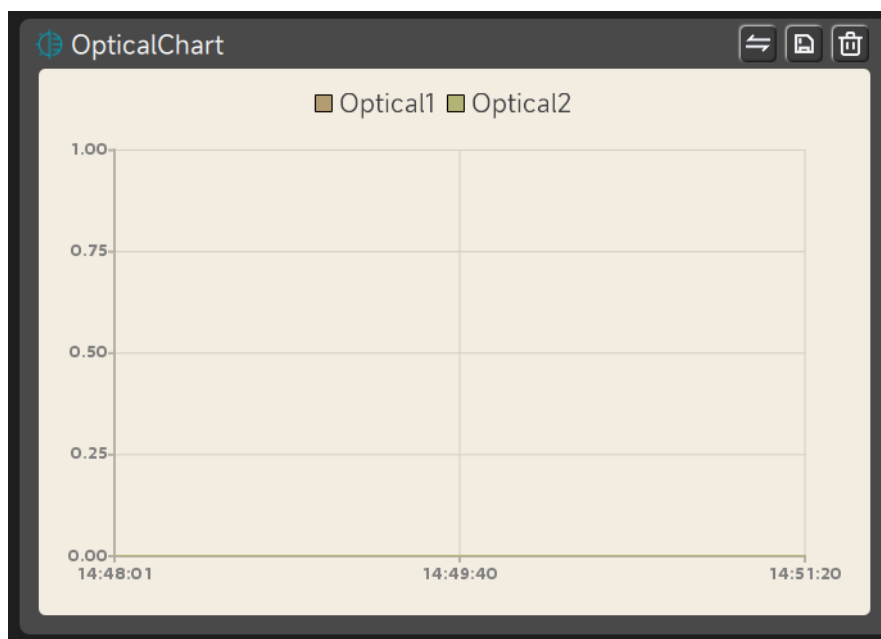

The 3 buttons in the upper right corner function to **switch curves**, **save waveforms** and **reset charts respectively**.

- The switch curve button on the top chart can switch the **light sensitivity** and **temperature curves**, and the bottom button can switch the **pump current** and **laser power curves**
- Save waveform function can save all waveform data from software startup or last reset to current time (no more than 7\*24 hours)
- Reset chart function can clear all historical waveform data and initialize the chart

## Annex 2 **SAKER series fiber laser WeChat applet use manual**

### I 、 General

The WeChat applet can read the laser operation status, alarm information, device activation, parameter setting and other functions in real time via Bluetooth.

The WeChat applet software described in this manual is applicable to Falcon series fiber lasers (model RXXXXXXXXX).

### II 、 Access Method

Enter the small program by scanning the small program code posted on the machine.

Enter the small program by following the official public number of ' **CinaLaser** '.

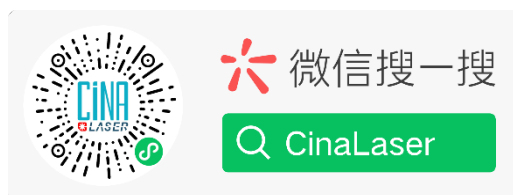

### III、 Instructions for using small programs

#### 1. Connecting Devices

Click the "Search" button at the top right of the main interface of the applet, search for nearby devices, select the device name CINA-XXXX, and click "Connect". After successful connection, the phone will vibrate and jump to the home page automatically. If the connection fails, you can try to reconnect, and if the connection fails several times, you can restart the WeChat applet and try the above steps again.

#### 2. Homepage Status Introduction

In the right figure, the middle of the first line will show the connected device connection name after successful connection, and the count of successful packet parsing reported by the device at the bottom will be incremented, if the count remains the same, it means that the packet is not successfully parsed.

If the following conditions occur, **contact the manufacturer for time calibration and reactivation.**

1. The device is in the trial period and the clock status is displayed incorrectly, if it is permanently





activated, you do not need to care about the clock status and the date of the device

2. The storage status shows an error
3. Expiration date is shown as expired

**If the device status parameter is abnormal, the display parameter will change color.**

### 3. Internal Control Settings

The internal control setting is used for testing the light output function of the laser.

This page contains the light output parameters setting and the function switching of light output, light off, and internal and external control.

The light output parameters include laser peak power, laser PWM frequency, laser PWM duty cycle, and single light output duration.



### 4. Advanced Settings

Advanced settings are mainly used to set some factory parameters and alarm thresholds for the laser.

微信搜一搜