

PDL976-350-200 High Power Diode Laser

PN: DL976330200

PRODUCT FEATURES

- ▶ Multiple single emitter based diode laser, high reliability
- ▶ 1040-1200nm feedback protection

MAIN APPLICATION

- ▶ Fiber laser pumping
- ▶ Direct applications



TECHNICAL INDEX

Performance			Index		
			Min.	Typ.	Max.
Optical Parameters ¹	Output Power	(W)		350	
	Center Wavelength ²	(nm)	973	976	979
	Spectral Width	(nm)		6	
	95% Power Within NA	(NA)		0.16	
	Back Reflection Isolation Range	(nm)	1040	1064	1200
	Back Reflection Isolation	(dB)	30		
Fiber Parameters	Fiber Core Diameter	(μm)	196	200	204
	Fiber Clad Diameter	(μm)	217	220	223
	Numerical Aperture	(NA)	0.20	0.22	0.24
	Fiber Length ²	(m)	1.5	2.0	
	Loose Tubing Diameter	(mm)	1.1	1.4	
	Loose Tubing length	(m)	1.2	1.5	
	Fiber Connector		Bare Fiber/SC Ceramic Ferrule		
	Fiber Bend Radius	(mm)	60		

Electrical Parameters ³	Conversion Efficiency	(%)		48	
	Threshold Current	(A)		1.1	
	Operating Current ³	(A)		25.0	26.0
	Operating Voltage ³	(V)			30.0
Thermal Parameters ³	Operating Temperature ⁴	(°C)	5		45
	Storage Temperature	(°C)	-30		85
	Wavelength Temperature Coefficient	(nm/°C)		0.35	
	Lead Soldering Temperature	(°C)		260	300
	Lead Soldering Time	(s)			10

1. Tested at 25°C cold plate temperature.
2. Others available upon request.
3. Reduced lifetime if used above nominal operating conditions.
4. Laser Wavelength would shift when package operating temperature is changed

SIZE

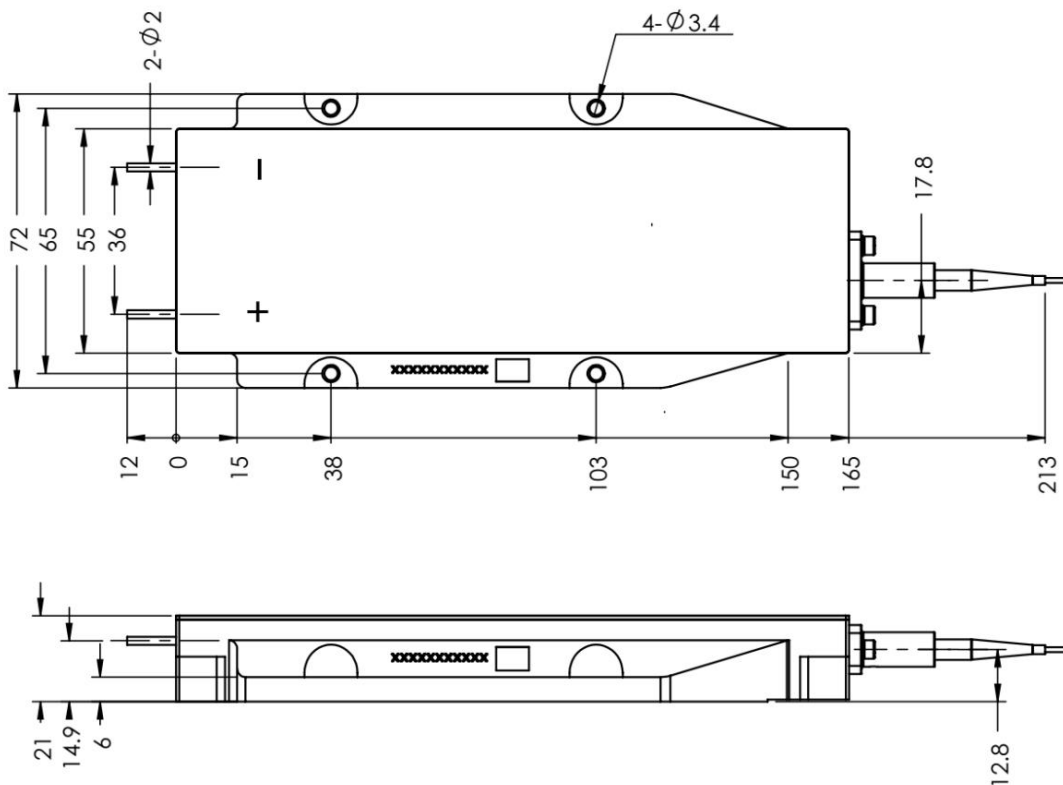

APPLICATION NOTES:

1. The laser beam emitted from the diode laser is invisible, please follow the standard safety procedures for IEC Class 4 lasers, avoid eye or skin exposure to direct or scattered radiation;
2. ESD is the primary cause of unexpected diode laser failure. The diode laser should be handled by trained operators wearing ESD grounding straps and the work surface should be grounded. Connectors should be attached to the pump pins prior to removing the ESD shortcut protection component;
3. Ensure the end of the fiber be free of dust and contamination before operation.
4. The laser should be operated according to the specifications, maximum optical power should not be exceeded;
5. The laser may be damaged by excessive drive current, stable power supply should be used to avoid surge current;
6. To ensure long-term reliability of the laser, a 20 - 30°C cold plate is needed to make the laser work within proper temperature range.

MODEL EXPLANATION

PDL
9
7
6
-
3
5
0
-
2
0
0

High Power Diode Laser	Operating Wavelength		Output Power		Output Fiber	
	Wavelength	nm	Power	W	Fiber	μm
	976	976	350	350	200	200/220
	915	915	140	140	105	105/125
	940	940	200	200	106.5	106.5/125
			240	240	135	135/155
			330	330	220	220/242
			370	370		
			540	540		